



The I-TRON street lighting luminaire family is characterized by high energy efficiency, excellent performance and high reliability. The family members are available in two sizes: I-TRON Zero and I-TRON 1. Both versions are part of AEC's "green light" products and are manufactured with a special high-purity aluminum optics, which provides excellent illumination levels for various road lighting applications.

Technical Data

Power consumption: 14.5...57W

Power supply: 220-240V, 50/60Hz; Insulation class : I - II.

LED modules: 525 mA, 160 lm/W, 4000K CRI ≥ 70 ; power factor (in full load): > 0.95

Protection degree: IP66, Mechanical resistance: IK08

Mounting: bracket or post-top $\varnothing 60$ mm, $\varnothing 32$ mm, $\varnothing 42$ mm, $\varnothing 48$ mm, $\varnothing 76$ mm for option.

Gear tray: removable – integrated in the luminaire and separated from the optic compartment.

Optikai rendszer: STU-M / STU-S és STU-W: asymmetrical optics for street urban and suburban lighting.

Materials:

Fixing, lower frame and upper canopy: die-cast aluminum UNI EN1706 powder painted.

Closure hook: captive screws in stainless steel

Screen: flat tempered glass, 4mm thickness. High transparency.

Cable gland: membrane IP66 – M20 IP68 optional

Gasket: polyurethane

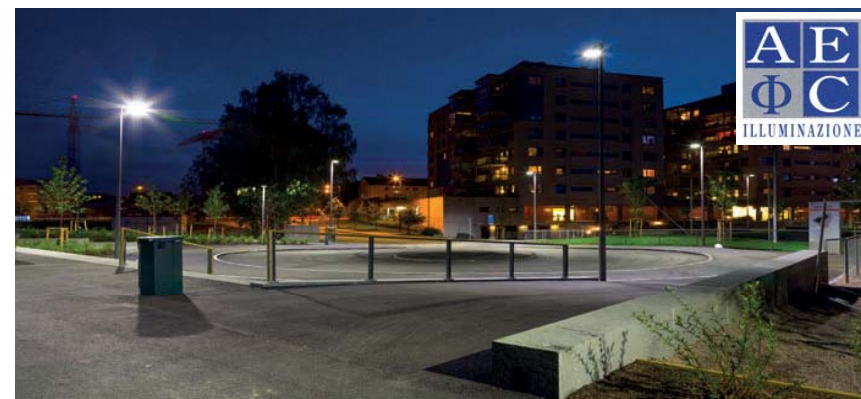

Dimensions

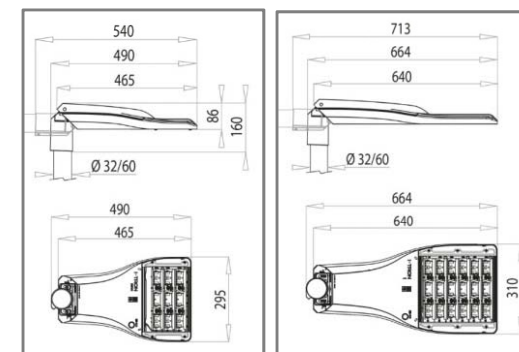

Luminous Intensity Distribution

STU-M

STU-S

STU-W

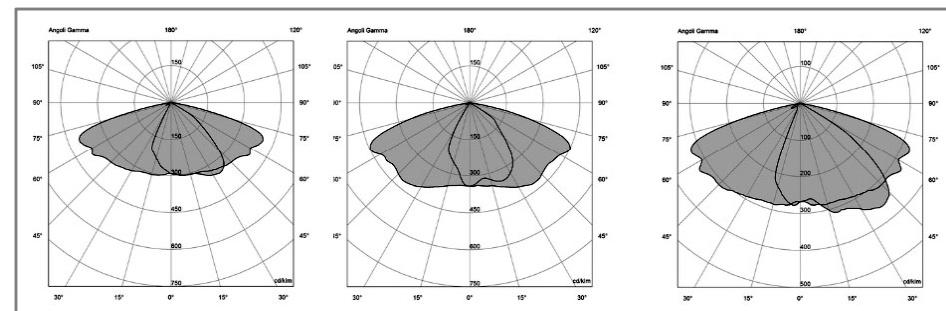

Don't hesitate to contact our experts: Mónika Hosó (T: (06 1) 450 2701); István Hajdrik (T: (06 1) 450 2712); Balázs Lévai (T: (06 1) 450 2711); György Jánoska (T: 06 1) 450-2714)